



Screw Blowers

DBS, EBS, FBS Series

With the world-renowned SIGMA PROFILE

Flow rate 6 to 67 m³/min, Pressure differential up to 1.1 bar

DBS, EBS, FBS series

The rotors in KAESER KOMPRESSOREN's new DBS, EBS and FBS series screw blowers are descended from the world-renowned SIGMA PROFILE and have been designed to meet the specialised needs associated with blower applications. So, just like their compressor counterparts, KAESER's screw blowers deliver more air and more savings. Together, the blower airend and the premium quality mechanical and electrical components create a powerful, energy-efficient turnkey blower system with forward-thinking design.

Efficient operation

KAESER screw blowers use up to 35 percent less energy than conventional rotary blowers and also achieve significant energy savings compared to other currently available low pressure compressors. The combination of a blower airend with high efficiency SIGMA PROFILE rotors, flow-optimised components, efficient power transmission and high efficiency drive motors ensures exceptional performance, guaranteed by KAESER in accordance with the stringent tolerances of ISO 1217.

Long-term dependability

Renowned throughout the world for their quality design, components and manufacture, KAESER products provide long-term machine and process availability you can count on. Quality features include durable rotor bearings, dependable power transmission, specifically dimensioned drive motors, torsion-free sound enclosures with effective cooling air flow, SIGMA CONTROL 2 machine controller for efficient and dependable operation – there are too many to list!

Cool and quiet

KAESER screw blowers also master the balancing act between best possible damping of structure- and fluid-borne noise and optimised cooling of the blower airend, drive motor and intake air. In fact the reduction of fluid-borne noise – i.e. pulsations caused by the compressed process air that are conveyed in the connected pipework – has been refined to the point of perfection.

Air at the press of a button

Delivered as user-friendly, turnkey systems, KAESER screw blowers simply need to be installed in position, connected to the air distribution network and the electrical supply and you're ready to go! The laborious processes of oil-filling, drive belt installation, motor adjustment, procurement of a suitable frequency converter, programming, cabling in accordance with EMC regulations, drawing circuit diagrams, organising CE and EMC certification are thankfully things of the past.

There's no doubt about it: complete, certified machines from systems providers save time and money while delivering many years of dependable operation.

Maximum efficiency: IE3 motors

Users can enjoy the benefits that these premium efficiency motors have to offer by choosing KAESER screw blowers.

Guaranteed performance specifications

To ensure that you benefit from the projected savings during actual operation, KAESER provides you with the effective overall power consumption data, as well as the usable flow rate, in accordance with the stringent tolerances of ISO 1217, Appendix C, or E as applicable.



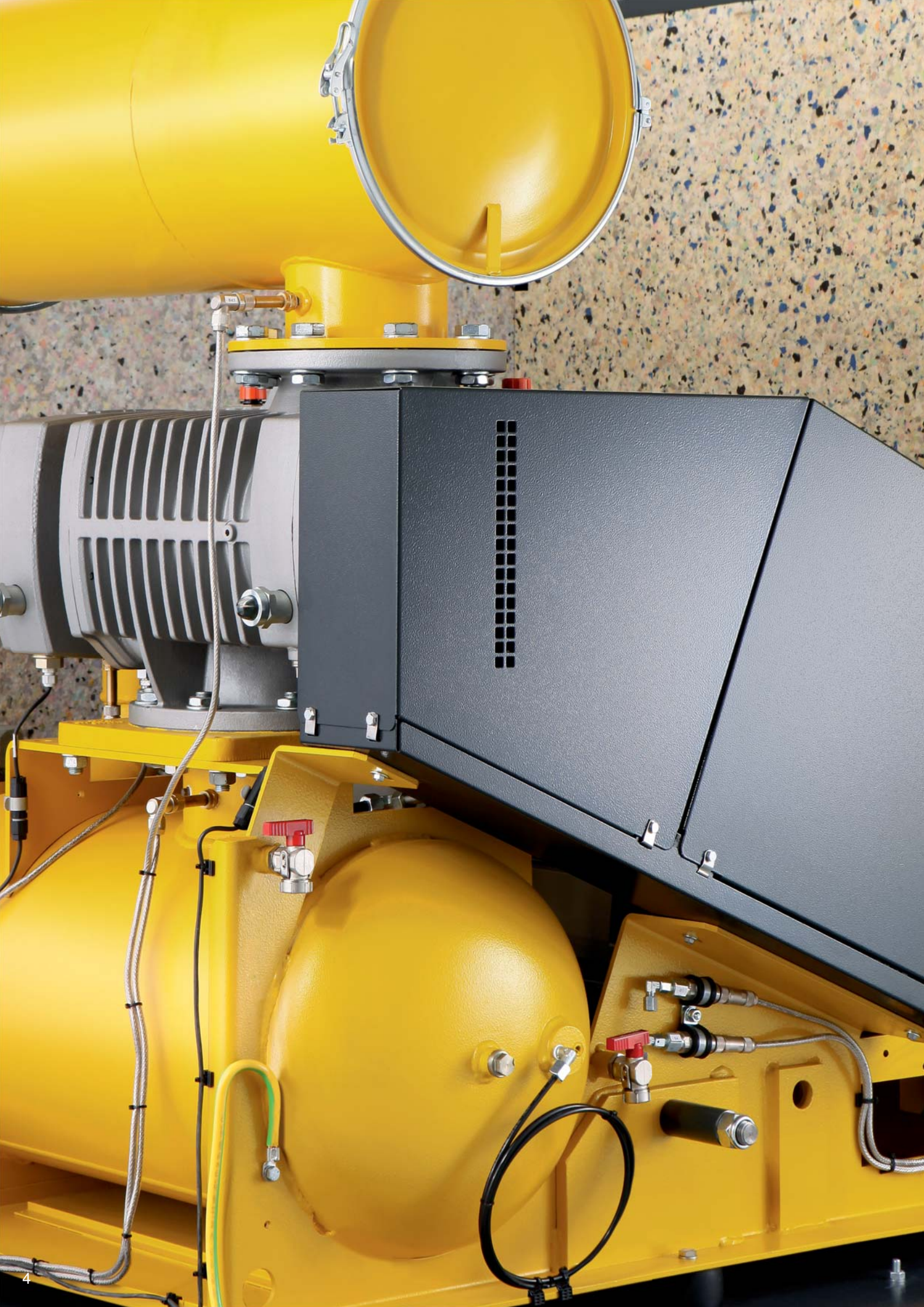

DBS, EBS, FBS series

Pure efficiency with the SIGMA PROFILE

Developed by KAESER in the early 1970s, the company's proprietary SIGMA PROFILE rotor technology revolutionised energy efficiency in the rotary screw compressor sector. Further refined in the KAESER Research and Development Centres in Coburg and Gera, this high-efficiency compressor technology is now also available for users in the blower sector.



Blower air end with SIGMA PROFILE

KAESER's high-efficiency blower air ends combine a wide control range with near constant specific power. Equipped with energy-efficient SIGMA PROFILE rotors, they ensure maximum air delivery and keep power consumption to an absolute minimum.



Dependable seals

Field-proven in KAESER rotary screw compressors, the sliding ring seal on the rotary transmission drive shaft lead-through of the screw blower air end is maintenance-free and provides dependable sealing, even in hot and/or dusty environments.



Durable bearings

All radial forces are borne by four robust cylinder roller bearings, which are rated to ensure long screw blower air end service life. The rollers are encased in high-tech cages for optimum lubrication at all speeds.



Continuous system monitoring

Sensors for oil level and temperature monitoring are integrated into the blower air end. The oil chamber is designed to ensure this functionality even during machine operation when the oil level is fluctuating.

DBS series

Direct drive – Ultimate efficiency



In DBS series screw blowers, power is transferred from the motor to the blower airend via an integrated gear transmission. Following detailed examination in the KAESER Research and Development Centres, this was found to be the most effective transmission solution for the speeds in this power and size class with regards to efficiency, dependability and durability.

The transmission ratio can be varied using various gear sets so that the motor, for example, remains usable at all times within in the optimum frequency range of the SFC frequency control, or, with fixed speed operation for example, the flow rate can be matched to suit actual demand. Highly durable and wear-free, this power transmission system operates at near 100 percent transmission efficiency and enables the use of standard electrical motors for the blower drive.

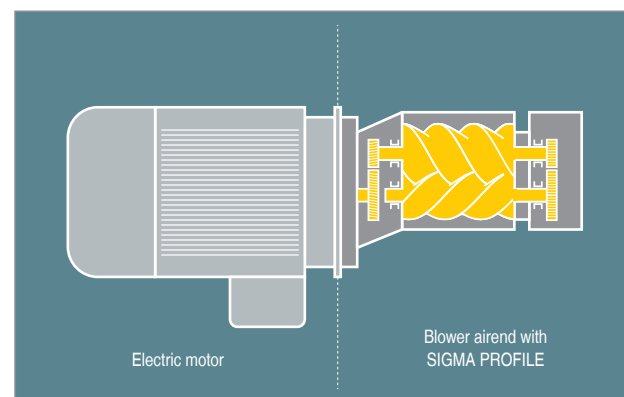

SIGMA B blower airend

With its high degree of efficiency and optimal reliability, this airend does not require auxiliary equipment such as an oil or vacuum pump, an oil cooler or aerosol separator.

EBS / FBS series

Belt drive – Refined to perfection

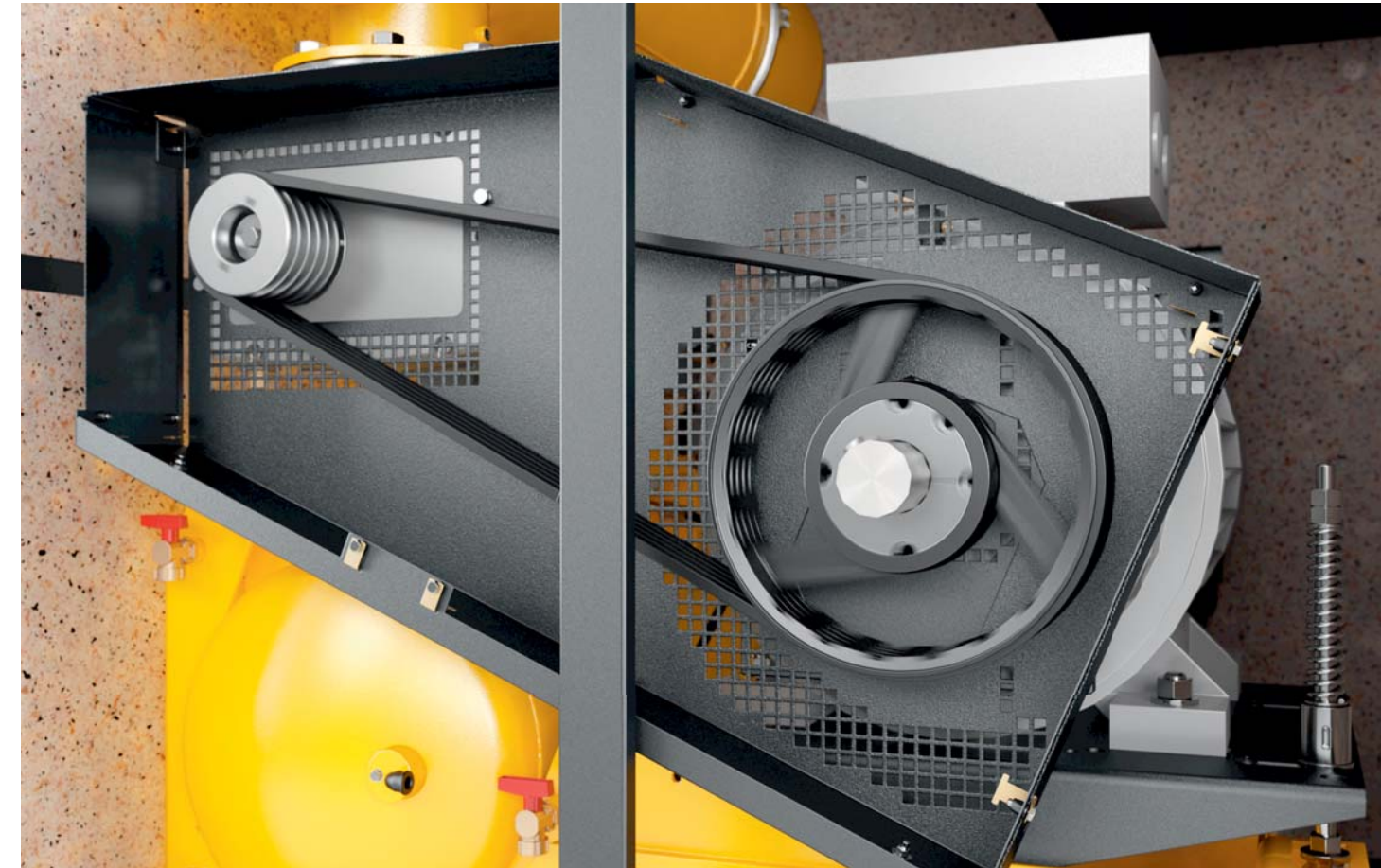

Automatic tensioning and tension indicator

The pivoting motor base with tensioning spring ensures precision belt tensioning irrespective of motor weight to provide optimum transmission efficiency.

KAESER screw compressors with V-belt drive provide outstanding efficiency and reliability. As a result of KAESER's decades of experience in compressor design and engineering, this power transmission method has been refined to perfection.

The automatic tensioning device ensures that the V-belt drive provides the best possible degree of transmission efficiency at all times throughout the KAESER screw blower's service life. This, of course, also reduces maintenance costs.

The solid V-belt guard protects operating personnel as stipulated in the EC Machinery Directive and allows effective re-lubrication with even grease distribution in the motor bearings – which is possible only during operation.

The belt guard's clever design as a 'wind tunnel' reduces temperature and consequently not only increases belt service life, but also that of the drive shaft seals on the airend and motor.

DBS, EBS, FBS series

Efficient and dependable

The blower airend plays a pivotal role in ensuring outstanding energy efficiency. It achieves this in combination with carefully matched components and the advanced SIGMA CONTROL 2 blower controller.



The blower controller

The SIGMA CONTROL 2 ensures efficient blower control and system monitoring. The generously sized display, RFID reader and numerous interfaces enable fast, reliable communication, whilst the SD card slot makes data storage and software updates a breeze.



Comprehensive sensors

A wide range of sensors and switches for monitoring pressure, temperature, speed, oil level and filters ensures dependable blower operation and allows remote monitoring and visualisation of operational status.



Cool inlet air

Cooling air for the motor and process air are drawn in separately from outside the sound enclosure. This boosts efficiency and leads to a higher usable mass flow rate for the same power consumption. The blowers can operate in ambient temperatures of up to +45 °C.

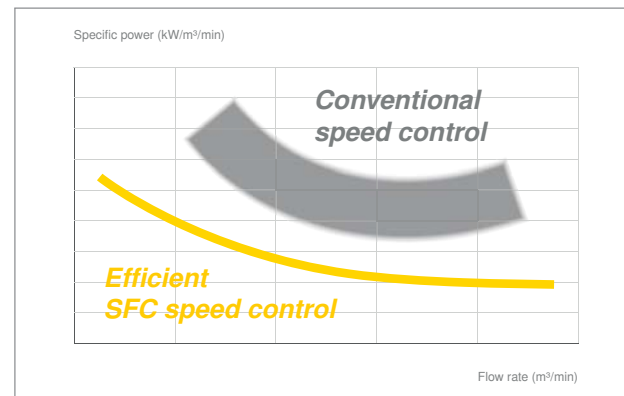

Optimised specific power

The moderate maximum speed, the extra dense screw profile and the near-constant specific power across the wide variable speed control range all combine to achieve significant energy savings throughout the entire operating curve.



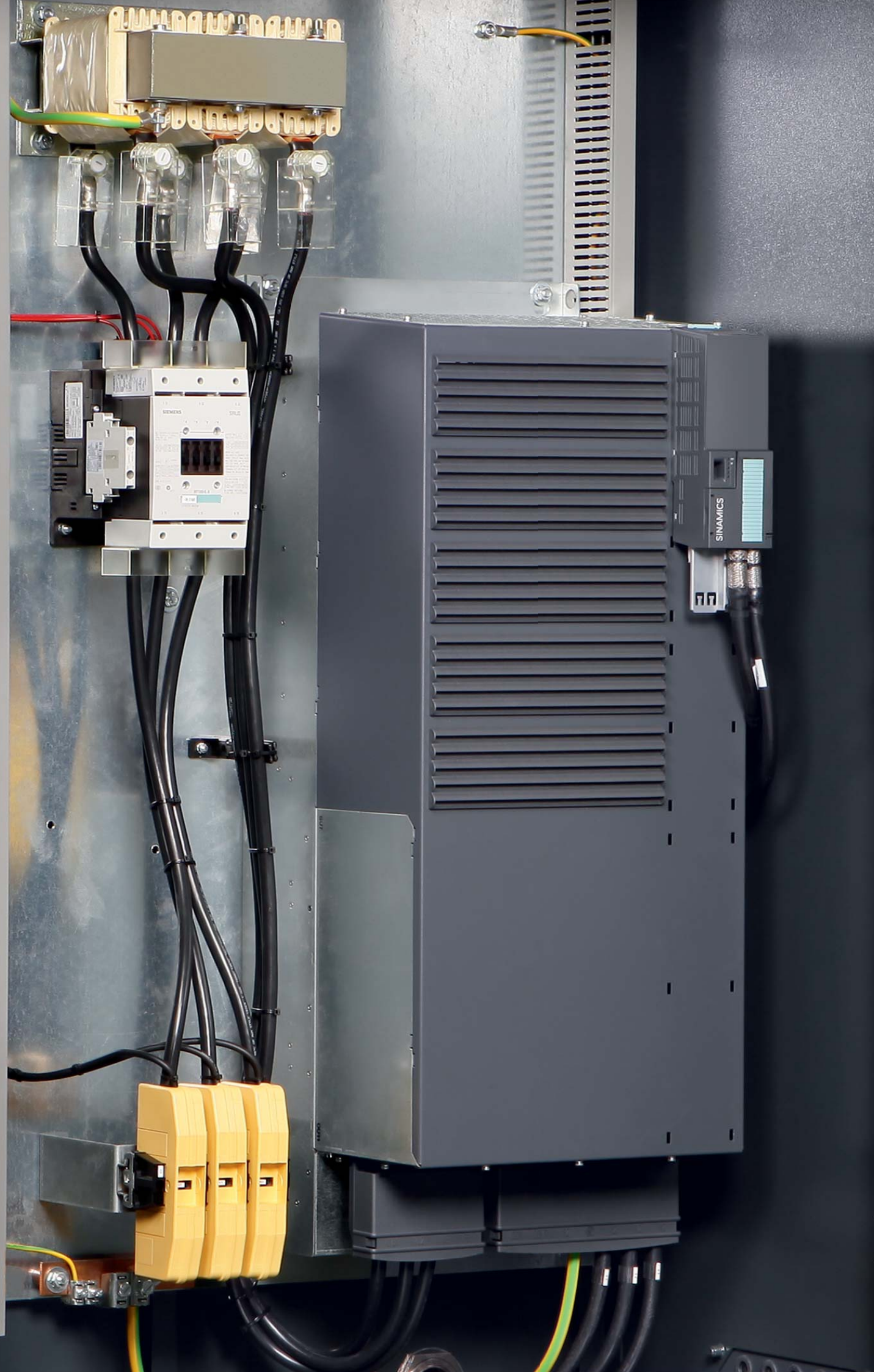

DBS, EBS, FBS series

Plug-and-play

KAESER screw blowers are turnkey complete machines. Users therefore benefit from not having to endure a time- and cost-intensive installation procedure. Moreover, the machines are ready ex-works for integration into Industry 4.0 environments.



Image: EBS, FBS STC principle



Image: EBS, FBS SFC principle

START CONTROL (STC)

The version with integrated star-delta starter for constant speed operation is equipped with a premium contactor, overload protection cut-out and phase loss monitoring. The SIGMA CONTROL 2 and a dependable emergency stop system round out the package.

SIGMA FREQUENCY CONTROL (SFC)

Using variable speed control, the SFC frequency converter adjusts blower performance to match application air demand. Everything is ready for immediate operation, since all programming and parametrisation is performed at the factory.



Plug-and-play

The turnkey blowers come complete with sensors, STC/SFC, SIGMA CONTROL 2 and an emergency stop switch, and are ready-filled with oil and fully certified. This significantly reduces the work and costs required for planning, installation, certification, documentation and commissioning.



EMC-certified

It goes without saying that the SFC control cabinet and SIGMA CONTROL 2 are tested and certified as individual components together with the complete blower system to EMC directive EN 55011 for Class A1 industrial power supplies.

DBS series

The new standard in the low pressure sector

Like their bigger siblings, the EBS and FBS, the new KAESER DBS screw blowers also impress with their exceptionally high cost-saving potential.



Exceptionally compact

Comprising a blower airend with drive, loss-free power transmission, silencers, sensors, control and electrical equipment, such as e.g. a frequency converter or star-delta, this compact powerhouse has a footprint of only 1.65 square metres.



Side-by-side installation

The package layout of DBS series screw blowers has been designed to allow all maintenance work to be performed from the front of the unit. These compact blowers can therefore be installed side-by-side without the need for any additional work.



Flow-optimised

All relevant components, even on the intake side, are flow-optimised to minimise pressure losses. Silencers, air filters and non-return valves also help to achieve "More air with more savings".



Even quieter

Highly effective sound dampening not only minimises actual machine sound thanks to the sound enclosure; special absorption silencers also help to significantly reduce the fluid-borne noise transmitted by piping that is commonly associated with frequency-controlled blowers.

More air per kilowatt



Image: DBS 220 M SFC

OIL.FREE

KAESER

GEBLÄSE 3

SFC

EBS 380 L

SIGMA

Equipment

IE3 motor

Premium efficiency IE3 motor from Siemens, three PTC thermistors or PT 100 as standard; variable speed drive models matched to SFC frequency converter. Service is made quick and cost-effective thanks to easy access central lubrication points for motors with re-greasable motor bearings.

SIGMA CONTROL 2

“Traffic light” LED indicators show operational status at a glance, plain text display, 30 selectable languages, soft-touch keys with icons, fully automated monitoring and control. Interfaces – Ethernet; additional optional communication modules for: Profibus DP, Modbus, Profinet and Devicenet. RFID card reader, web server, KAESER CONNECT user interface, visualisation of signals at analogue and digital inputs, warning and alarm messages, graphical display of pressure, temperature and speed trend. SD card reader for storage of data relating to process data, operating hours, working hours as well as warning and alarm messages on a SD card. Update upload via SD card.

Pulsation dampener

Efficient inlet and discharge side absorption silencers have a wide frequency range to mitigate unwanted process air pulsations; excellent damping of fluid-borne noise transmitted by piping.

KAESER-CONNECT

Create a LAN connection between a PC and the SIGMA CONTROL 2; launch Internet browser; enter SIGMA CONTROL 2 IP address and password: access blower control via integrated web server. The user interface shows machine status in real-time, the signals at the analogue and digital inputs, lists warning and alarm messages and graphically displays pressure, temperature and speed trends.

(see image below)

Additional optimisation



SIGMA AIR MANAGER 4.0

The SIGMA CONTROL 2 internal compressor / blower controller and the SIGMA AIR MANAGER 4.0 provide more than just optimised blower air system efficiency. Thanks to their high level of data integration and multiple interface options, they can be easily integrated into advanced production, building management and energy management systems, as well as Industry 4.0 environments.

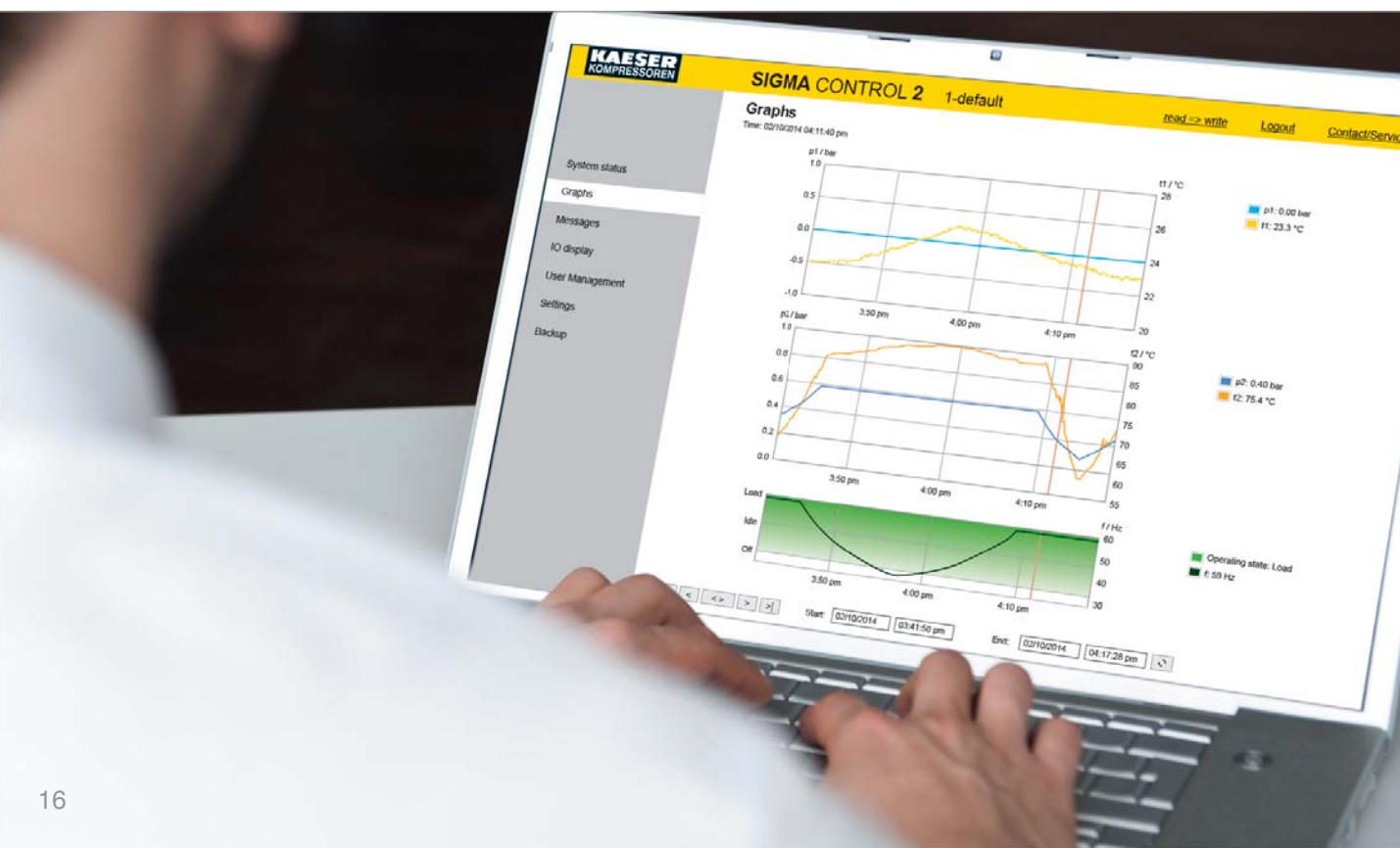

Optimum conditions

Carefully matched peripheral components such as weather protection screens, supplementary fans and sound dampers in inlet and outlet ducts, for example, help to maintain a pleasant working environment.



Heat recovery

Heat exchangers can significantly cool the process air even at high ambient temperatures. The gained recyclable heat can be utilised for space heating and/or hot water heating, thereby drastically reducing primary energy costs.



Cooler

With minimal pressure drop, the efficient ACA-type air/air aftercooler uses a temperature switch to reliably limit blower air temperature to 10 Kelvin above ambient.

Design

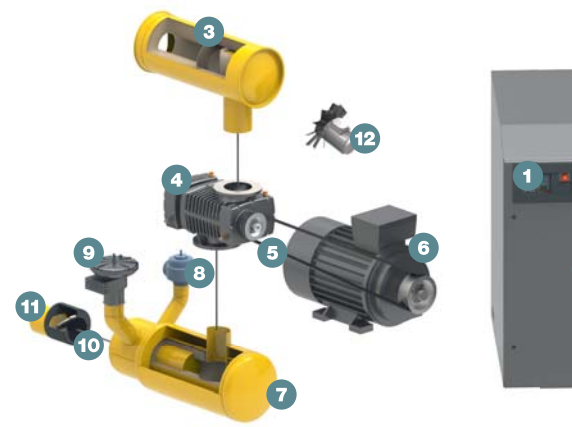
DBS	EBS, FBS
	
01) SIGMA CONTROL 2 control system 02) STC or SFC control cabinet 03) Intake silencer with filter 04) SIGMA B blower airend 05) V-belt 06) IE3 premium efficiency motor	07) Compressed air silencer 08) Pressure valve 09) Unloaded-start valve (optional) 10) Check valve (optional) 11) Expansion joint 12) Fan sound enclosure

Technical specifications

Model	Operating pressure		Max. rated motor power kW	Pipe connection DN	Dimensions with control cabinet W x D x H mm	Mass max. kg
	Max. pressure differential mbar	Max. flow rate ¹⁾ m³/min				
DBS 220 L SFC	650	23	30	100	1110 x 1480 x 1670	820
DBS 220 M SFC	1100	22	37			850
DBS 220 L STC	650	19	22			800
DBS 220 M STC	1100	18	37			850
EB 380S L SFC	650	38	45	150	1940 x 1600 x 1700	1400
EB 380S M SFC	1100	37	75			1600
EB 380S L STC	650	36.5	45			1400
EB 380S M STC	1100	36	75			1600
FB 660S L SFC	650	67	75	200	2250 x 1950 x 1900	1850
FB 660S M SFC	1100	66	110			2200
FB 660S L STC	650	66	75			1850
FB 660S M STC	1100	65	110			2200

¹⁾ Performance data as per ISO 1217, Appendix C for STC version, Appendix E for SFC version







Detailed customer-specific planning



Using data gathered from KAESER's proprietary AIR DEMAND ANALYSIS 4.0 (ADA 4.0) technology, the KAESER ENERGY SAVING SYSTEM 4.0 (KESS 4.0) provides comprehensive analysis of your blower air usage, enabling KAESER's experts to plan and design a system that is specifically tailored to meet all of your blower air needs. Blower systems designed by KAESER ensure exceptional efficiency and availability for your application.

By having a perfect combination of blowers customised to meet your individual requirements, you will benefit from unrivalled supply dependability and performance. Use this expertise to your advantage and let KAESER KOMPRESSOREN design your blower air system.

Views

DBS				
				
EBS				
				
FBS				
				

The world is our home

As one of the world's largest compressed air systems providers and compressor manufacturers, KAESER KOMPRESSOREN is represented throughout the world by a comprehensive network of branches, subsidiary companies and authorised partners.

With innovative products and services, KAESER KOMPRESSOREN's experienced consultants and engineers help customers to enhance their competitive edge by working in close partnership to develop progressive system concepts that continuously push the boundaries of performance and compressed air efficiency. Moreover, the decades of knowledge and expertise from this industry-leading system provider are made available to each and every customer via the KAESER group's global computer network.

These advantages, coupled with KAESER's worldwide service organisation, ensure that every product operates at the peak of its performance at all times and provides maximum availability.



HPC | Compressed
Air Systems

HPC Compressed Air Systems, Victoria Gardens, Burgess Hill, West Sussex RH15 9RQ
Tel: 01444 241671 Fax: 01444 247304 E-Mail: info@hpcplc.co.uk www.hpccompressors.co.uk